

AC AXIAL FAN Ø550

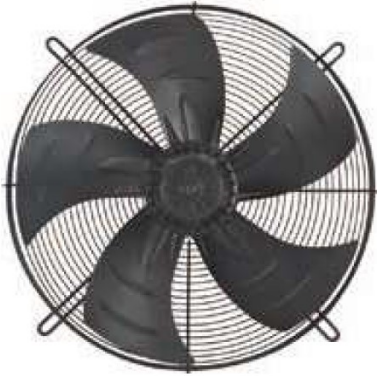

Product Characteristic

Motor technology: AC Outer rotor
 Mode of Operation: S1
 Protection Class: IP54
 Insulation Class: B/F
 Bearings: Maintenance-free ball bearings
 Blades Material: Cold rolled sheet steel
 Blades count: 5
 Air direction: seen on the leads

Flow Rate Curve

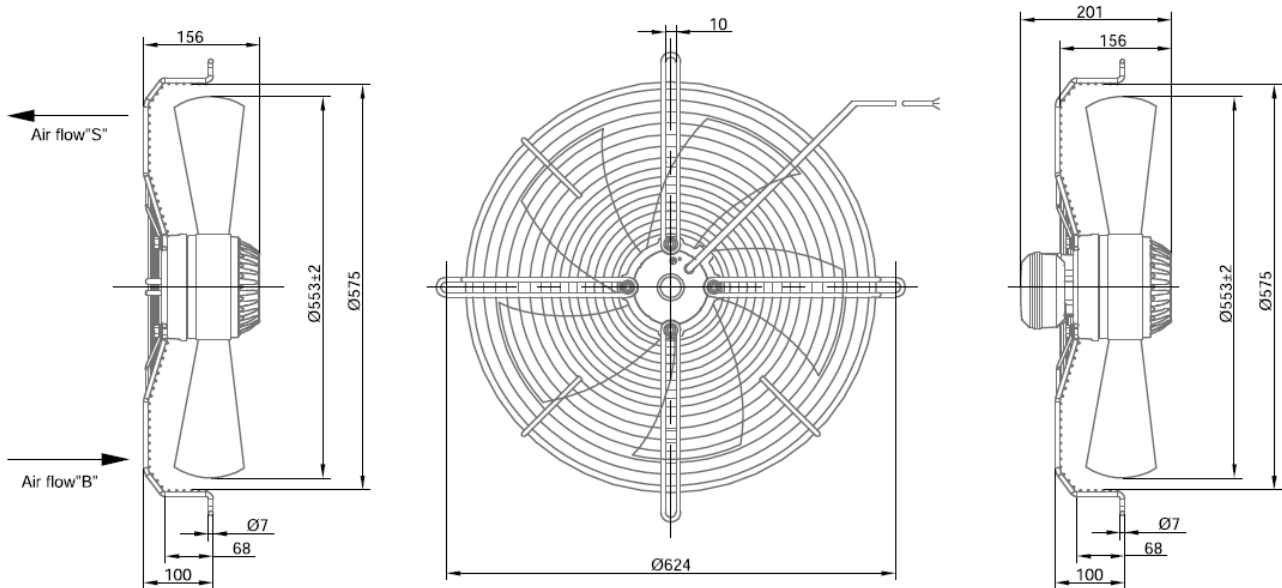
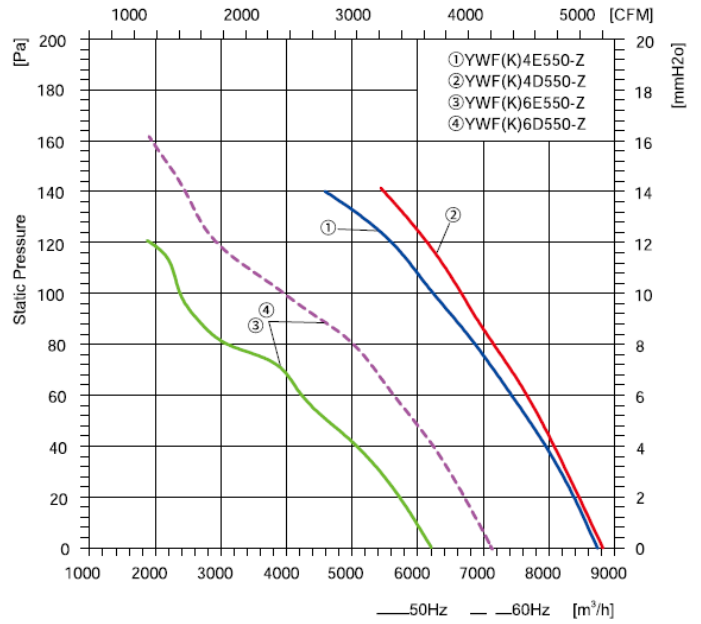

Model	Code	Voltage (V)	Frequency (Hz)	Input Power (W)	Current (A)	Air Volume (m³/h)	Speed (r/min)	Capacitor (µF)	Noise [(dB(A)]	Max Environmental Temperature (°C)	Weight (Kg)
YWF(K)4E550-Z	ZO4E550	230	50	550	2.45	8500	1310	12	74	50	10.5
YWF(K)4D550-Z	ZO4D550	380	50	650	1.2	8500	1300	-	74	50	10.5
YWF(K)6E550-Z	ZO6E550	230	50	330	1.68	6200	910	10	67	60	10.5
YWF(K)6D550-Z	ZO6D550	380	50	330	0.87	6200	900	-	67	60	10.5

Air Flow "B" = Blow "S" = Suck Needs to be specified when ordering