

Connect Phase (Live) to R and Neutral to S for single phase supply
Connection U/T1, V/T2, W/T3 go to the motor

Connect 3 phase input supply L1/R, L2/S, L3/T
Connection U/T1, V/T2, W/T3 go to the motor

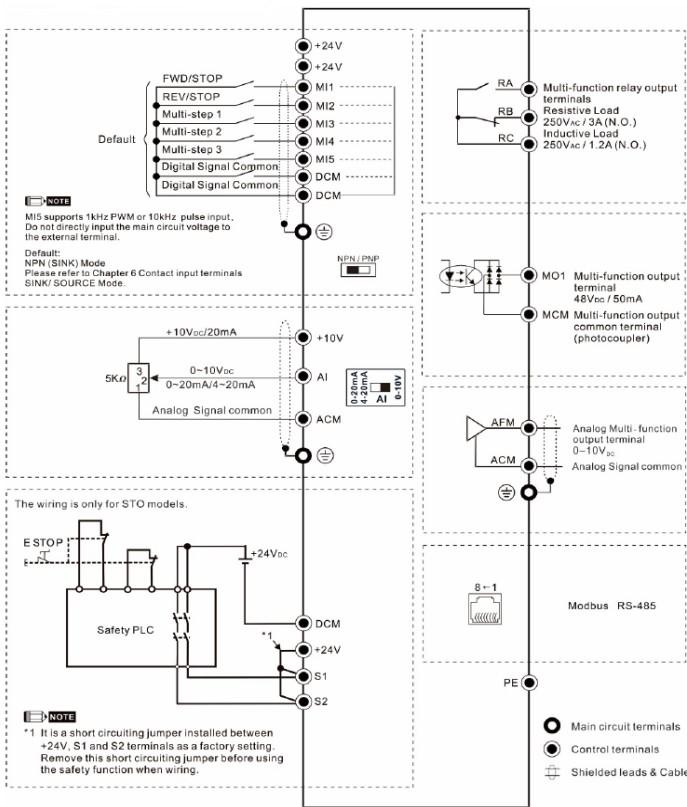

Instructions for Remote Setup (Remote On/Off and Speed Variation)

- For remote stop and start connect between DCM and MI1 (FWD) and MI2 (REV) (DCM is your common)
- For remote Potentiometer connect the potentiometer to +10V, AVI and ACM (common).
- Set **00.20** to 2 (Remote Potentiometer setting)
- Set **00.21** to 1 (Remote ON/OFF setting)
- Set **02.00** to 1 or 2 (2-wire operation control)

Pr.02-00	External Terminal Control Circuits	
Setting value: 1 Two-wire FWD / STOP REV / STOP		MI1 "OPEN": STOP "CLOSE": FWD MI2 "OPEN": STOP "CLOSE": REV DCM
Setting value: 2 Two-wire RUN / STOP FWD / REV		MI1 "OPEN": STOP "CLOSE": RUN MI2 "OPEN": FWD "CLOSE": REV DCM

- Set **02.00** to 3 (3-wire operation control)

Setting value: 3 Three-wire		MI1 "CLOSE": RUN MI3 "OPEN": STOP MI2 REV/FWD: "OPEN": FWD "CLOSE": REV DCM
--------------------------------	--	---

V/F curve set up (Factory setting is General purpose)

General purpose	230V		400V		Fan & Hydraulic	230V		400V		High starting torque	230V		400V	
	PR.	SETTING	PR.	SETTING		PR.	SETTING	PR.	SETTING		PR.	SETTING	PR.	SETTING
01-00	50	50	01-00	50	50	01-00	50	50	01-00	50	50	01-00	50	50
01-01	50	50	01-01	50	50	01-01	50	50	01-01	50	50	01-01	50	50
01-02	230	400	01-02	230	400	01-02	230	400	01-02	230	400	01-02	230	400
01-03	1.3	1.3	01-03	25	25	01-03	25	25	01-03	2.2	2.2	01-03	2.2	2.2
01-04	10	20	01-04	50	100	01-04	50	100	01-04	23	46	01-04	23	46
01-05	1.3	1.3	01-05	1.3	1.3	01-05	1.3	1.3	01-05	1.3	1.3	01-05	1.3	1.3
01-06	10	20	01-06	10	20	01-06	10	20	01-06	14	28	01-06	14	28



**QUICK SETUP INSTRUCTIONS FOR
 VARIABLE SPEED DRIVE
 1 PHASE TO 3 PHASE
 AND
 3 PHASE TO 3 PHASE**



VFD-ME300 Series



HAMILTON PH: 07 847 3374
CHRISTCHURCH PH: 03 666 3374
sales@rotatingmachinery.co.nz



AUCKLAND PH: 09 271 6063
info@brookmtl.co.nz

Important Notice

- Wiring and connection must be carried out by a registered electrician.
- Connection by an unqualified person voids the warranty.
- Please check the suitability of the motor before attempting to connect it to the device.
- Ensure the motor terminals are configured to suit supply from VSD, for 1ph supply VFD the motor must be connected in DELTA. For 3ph supply VFD please consult the motors name tag for 400V connection.



1. **Status Display** – Display the drives current status
2. **LED Display**— Indicates frequency, voltage, current, user defined units
3. **Potentiometer**— For local frequency setting
4. **Run Key**— to start drive locally
5. **UP & DOWN Key**— Used to change numerical numbers, frequency, parameters
6. **Mode**— Change between different display mode
7. **STOP/RESET**— Stops AC drive operation and resets the drive after a fault has occurred
8. **ENTER**— Used to enter and save the parameters

FOR ADVANCED SET UP REFER TO THE FULL MANUAL

www.rotatingmachinery.co.nz/products/drives

Quick Setup for Variable Speed Drive

Turn on power to unit and follow as below:

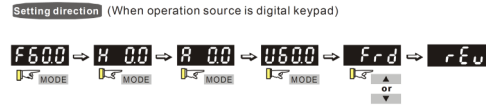

- Display will show ether F, H, A, U after power up.
- Press the enter button.
- 00. will appear on the screen, this is the parameter group.
- Use the up and down keys to change parameter group to the desired one. Press “ENTER”.
- 00.00 will appear on the screen, this is the sub group.
- Use the up and down keys to change parameters selections to the desired one. Press “ENTER”
- You will now be able to change the required setting of the parameter to the desired value or setting. Press “ENTER”. End will flash on your screen to indicate that your setting has been saved.
- Continue the above steps till all of your required parameters have been set.
- If you need to back out of a sub parameter group you can press the “MODE” button.
- Once all the parameters have been set press the “MODE” button till the F50.0 screen comes up again.

Displayed items	Descriptions
RUN FWD REV: F600	• STOP • PLC Displays the present frequency setting for the drive.
RUN FWD REV: H500	• STOP • PLC Displays the actual frequency output to the motor.
RUN FWD REV: U 18	• STOP • PLC Displays the user-defined output of a physical quantity. This example is for parameter Pr.00-04 = 30.
RUN FWD REV: A 50	• STOP • PLC Displays the load current.
RUN FWD REV: Frd	• STOP • PLC Forward command
RUN FWD REV: rEv	• STOP • PLC Reverse command
RUN FWD REV: c 20	• STOP • PLC Displays the count value.
RUN FWD REV: 0600	• STOP • PLC Displays a parameter item.
RUN FWD REV: 10	• STOP • PLC Displays the content of a parameter value.
RUN FWD REV: EF	• STOP • PLC Displays an external fault.
RUN FWD REV: End	• STOP • PLC Displays the data that has been accepted and automatically stored in the internal memory.
RUN FWD REV: Err	• STOP • PLC Displays the data set that is not accepted or has exceeded the value.

List of quick set up parameters

- **00.02** All parameters are reset to factory settings or 50Hz settings, set to 9 (must be none after initial powerup)
- **00.20** Source of master Frequency Command.
 - 0 = UP/DOWN arrow (Factory setting)
 - 2 = External analog input
 - 3 = External UP/DOWN terminals
 - 7 = Digital keypad potentiometer
- **00.21** Source of master Operation Command.
 - 0 = Digital keypad (Factory setting)
 - 1 = External terminals
- **01.00** Change to the maximum Frequency required
- **01.01** Change value to match Hz on motor nameplate
- **01.02** Change to match voltage on motor nameplate (Max Voltage output)
- **01.10** Upper limit Frequency
- **01.11** Lower limit Frequency
- **01.12** Acceleration time (factory setting 10sec)
- **01.13** Deceleration time (factory setting 10sec)
- **05.01** Set to Motor Name Plate Current
- **05.02** Set to Motor Name Plate kW
- **05.03** Set to Motor Name Plate Speed (rpm)
- **05.04** Set as the number of poles of the motor (3000rpm=2pole; 1500rpm=4pole; 1000rpm=6pole; 750rpm=8pole) (factory setting 4 pole)
- **05.00** Auto tuning, option 1 Dynamic test for induction motor = 1 (note motor must be unloaded), Static test for induction motor = 2, after the parameter number is entered press “MODE” button to return to main screen showing “F30.00 or F33.33”, press the “RUN” button to start auto tune, Auto tuning should only be preformed after all the data is entered.
- **06.13** Electronic thermal relay.
 - 0 = Inverter motor (with external forced cooling fitted)
 - 1 = Standard motor (motor with fan on shaft)
 - 2 = Disable (factory setting)

See back page for power and remote control connections and set up